

MUELLE LA OVEJA



2-8 AÑOS



0.45 m



13 m²



x= 0.85
y= 0.40
z= 0.90

Dimensiones:

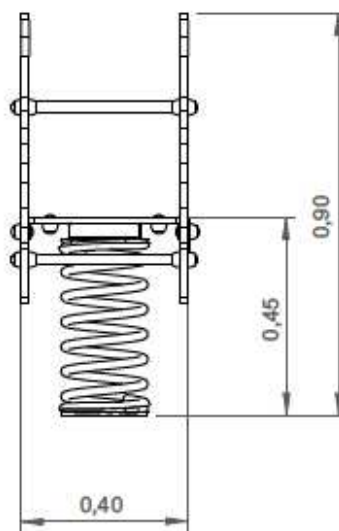
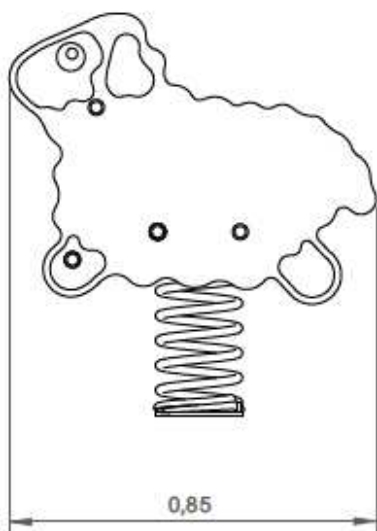

Área de seguridad:

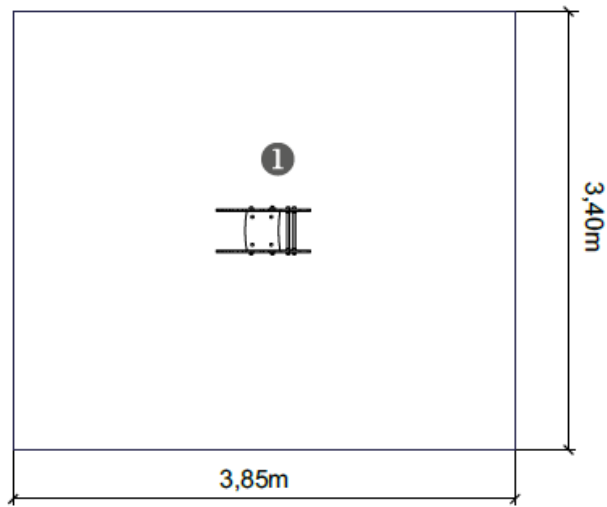

-----	①
	0,45
	13
	13



Información Técnica:

1 - Muelle 0.45m

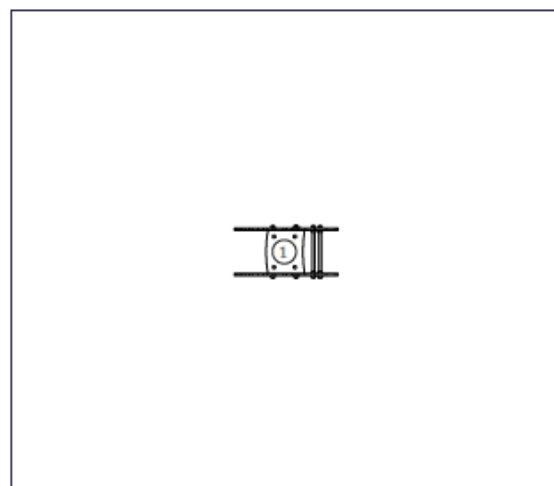

Características Técnicas:

- **Paneles fabricados en polietileno** de alta densidad, monocolor o bicolor. Resistente a productos químicos y corrosión. Alta resistencia al impacto y es muy difícil de romper. La superficie antideslizante proporciona seguridad para los niños y su base sintética impide el cultivo de bacterias y hongos. No requiere mantenimiento.
- **Muelle en espiral de acero 35 NCD** controlado en campo magnetoscópico. Superficie tratada con chorro de arena, zinc y dos capas de poliéster al polvo.
- **Tubos** de acero inoxidable AISI 304 de 25 mm de diámetro.
- **Acero galvanizado.**
- Tornillería en acero galvanizado, opcional acero inoxidable.
- **100 % Reciclable.**

